

RULES

This is a closed book, closed notes test. You are, however, allowed one piece of paper (front side only, hand-written) for notes and definitions. You must staple your equations sheet to the back of your test when you hand your test in.

You are permitted to use a calculator.

You have 75 minutes to complete the test. Please read through the entire test before starting, and read through the directions carefully. To receive partial credit, you must show your work.

If you have any questions, please raise your hand, and I will come to you to answer them. Do not hesitate to ask questions.

Circle/box all of your answers.

$$n_i=10^{10}\text{cm}^{-3}, \mu_n=1360\text{cm}^2/\text{Vs}, \mu_p=460\text{cm}^2/\text{Vs}, \tau_n=\tau_p=100\mu\text{s}, E_g=1.12\text{eV},$$
$$K_s=11.8, \epsilon_0=8.854\times 10^{-12}\text{F/m},$$
$$k=1.38\times 10^{-23}\text{J/K}, T=300\text{K}, q=1.602\times 10^{-19}\text{C}$$

Opamp Parameters $V_{\text{sat}} = \pm 5\text{V}$

Diode Parameters $V_{\text{ON}}=0.7, V_Z=5.6\text{V}, n=1, I_0=0.1\mu\text{A}$

Problem	Value	Score
1	20	
2	10	
3	10	
4	10	
5	20	
6	20	
7	10	
Total	100	

PROBLEM 1

(20 Points)

An amplifier has the following two-port model parameters

$$R_{in} = 1\text{M}\Omega$$

$$R_{out} = 1\text{k}\Omega$$

$$A_v = -10,000$$

(Note, this amplifier is a *unilateral* amplifier – there is no reverse transconductance)

A. Draw the two-port model using the parameters given. Use numerical values where applicable (for example, write $1\text{M}\Omega$ instead of R_{in}). (5 Points)

B. Convert this two-port model to have a Norton-style output. Provide numerical values for each of the parameters. (5 Points)

C. Determine the unloaded gain of this amplifier.

(2 Points)

D. This amplifier is now connected to a preceding circuit (represented by a Thevenin equivalent), and the amplifier drives the subsequent load resistance, R_L . Determine the gain going from V_{in} to V_{out} .

(8 Points)

$$R_S = 1\text{M}\Omega \quad R_L = 10\text{k}\Omega$$

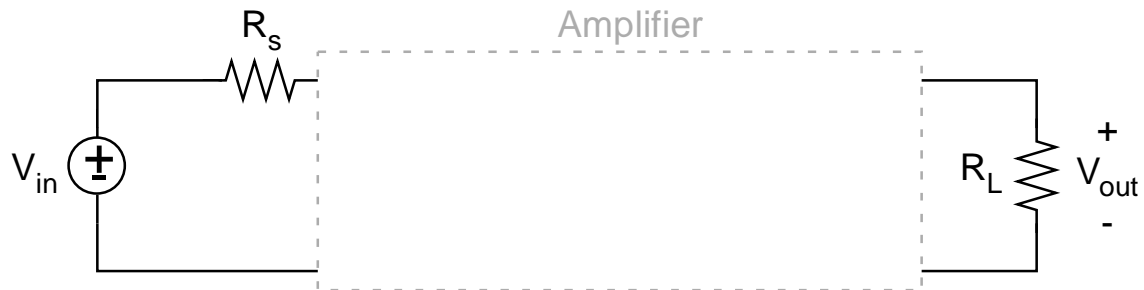

PROBLEM 2

(10 Points)

A. Draw the band diagram of a p-n junction with zero applied bias. Label all relevant energy levels and the p-type and n-type sides. (3 Points)

B. Draw the band diagram of a p-n junction with a reverse bias. Label all relevant energy levels and the p-type and n-type sides. (2 Points)

B. What type of thermal motion of charged particles is the primary mechanism of current flow in a reverse-biased diode? (1 Point)

B. Draw the forward bias current in a p-n junction on the axes that have been provided. Be sure to label all slopes, intercepts, and/or significant items. (4 Points)

Diode Current (Forward Bias)

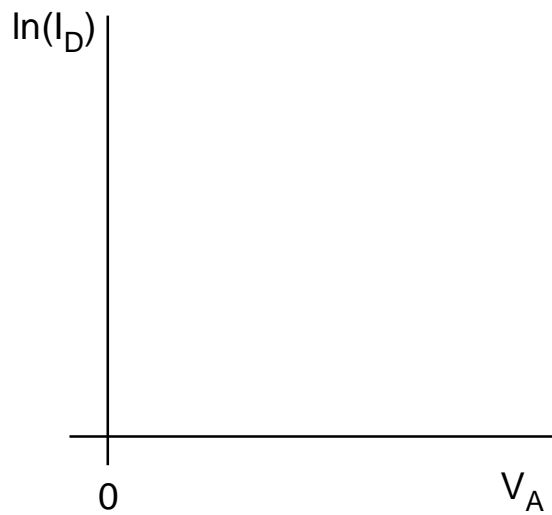

PROBLEM 3

(10 Points)

For the following circuit and the parameters given below, determine voltage gain.

$$R_1 = 1\text{k}\Omega \quad R_2 = 1\text{k}\Omega \quad R_3 = 3\text{k}\Omega$$

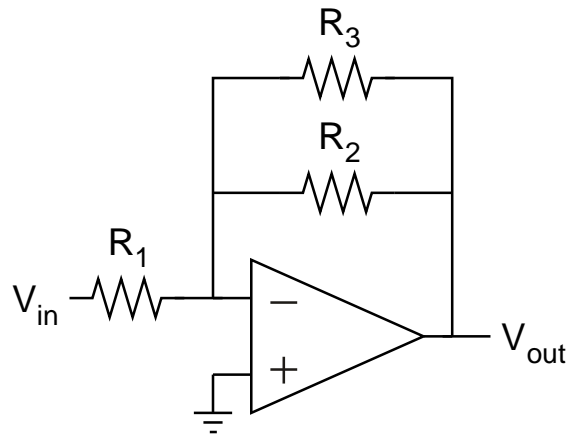

PROBLEM 4

(10 Points)

For the following circuit and the parameters given below, determine the output voltage and the current flowing through each resistor. Write your answers on the lines that have been provided.

$V_{in} = 1V$ $R_1 = 1k\Omega$ $R_2 = 2k\Omega$ $R_3 = 100\Omega$

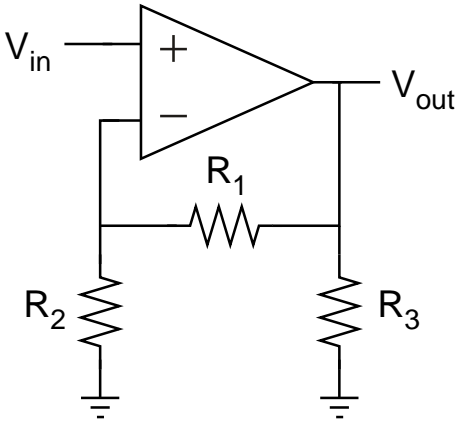

$V_{out} =$ _____

$I_{R1} =$ _____

$I_{R2} =$ _____

$I_{R3} =$ _____

PROBLEM 5

(20 Points)

For the following circuit and the parameters given below, sketch the time-domain waveform for V_{out} .

$$V_1 = (0.5)\cos(\omega t) \quad V_2 = 1V \quad R_1 = 1k\Omega \quad R_2 = 2k\Omega \quad R_3 = 1k\Omega$$

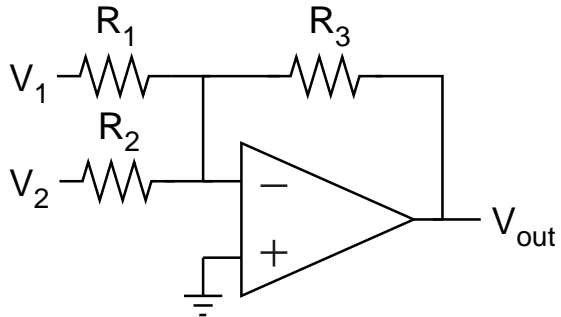

PROBLEM 6

(20 Points)

For the following circuit and the parameters given below, determine the input-to-output voltage relationship (i.e. transfer function). Sketch the transfer function in as much detail as possible on the axes that have been provided. Label all interesting items on the sketch.

$$V_{\text{ref}} = -1\text{V} \quad R_1 = 1\text{k}\Omega \quad R_2 = 3\text{k}\Omega$$

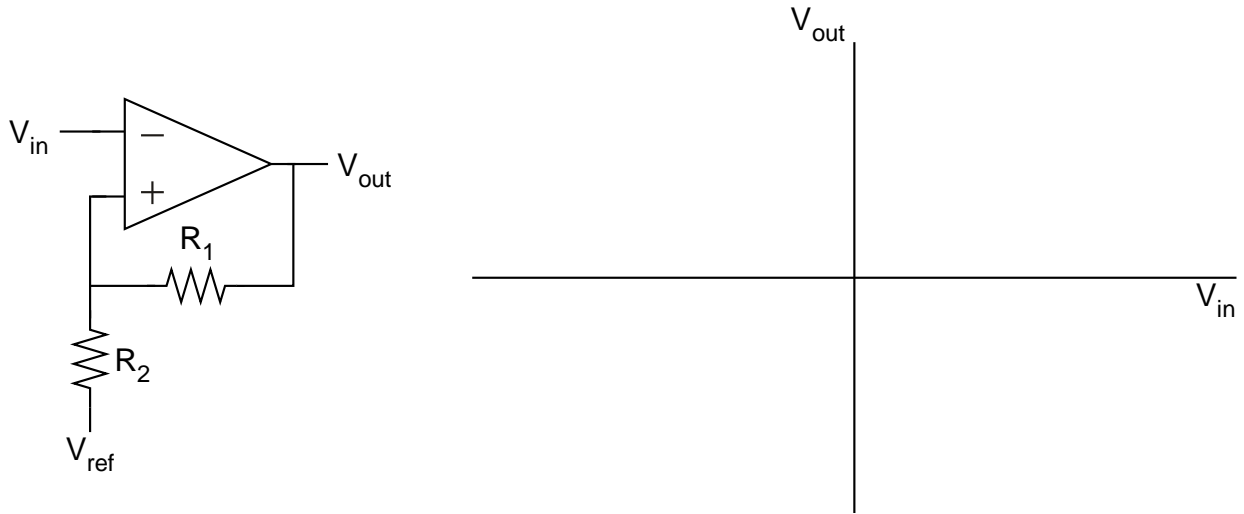

PROBLEM 7

(10 Points)

For the following circuit, the input signal is displayed below. Sketch the time-domain value V_{out} .

