

RULES

This is a closed book, closed notes test. You are, however, allowed one piece of paper (front and back) of handwritten notes and definitions, but no sample problems. You must staple your equations sheet to the back of your test when you hand your test in.

You are permitted to use a calculator.

You have 75 minutes to complete the test. Please read through the entire test before starting, and read through the directions carefully. To receive partial credit, you must show your work.

There is to be absolutely no cheating. Cheating will not be tolerated.

If you have any questions, please raise your hand, and I will come to you to answer them. Do not hesitate to ask questions.

Make sure you write all units in your answers.

Useful Parameters (Use Unless Otherwise Specified)			
$n_i=10^{10}\text{cm}^{-3}$	$\mu_n=1360\text{cm}^2/\text{Vs}$	$\mu_p=460\text{cm}^2/\text{Vs}$	$\tau_n=\tau_p=100\mu\text{s}$
$K_s=11.8$	$\epsilon_0=8.854\times 10^{-12}\text{F/m}$	$T=300\text{K}$	$E_g=1.12\text{eV}$
$ V_{T0} = 0.7\text{V}$	$\gamma = 0.45\text{V}^{1/2}$	$2\phi_F = 0.9\text{V}$	$I_{th} = 1\mu\text{A}$
$\kappa_n = \kappa_p = 0.65$ (sub V_T)	$\kappa_n = \kappa_p = 1$ (above V_T)	$I_0 = 1\text{pA}$	$K = 100\mu\text{A}/\text{V}^2$
$V_A = 50\text{V}$	$n=1$ (diode)	$q = 1.602\times 10^{-19}\text{C}$	$V_{dd} = 5\text{V}$
$k=1.38\times 10^{-23}\text{J/K}$	$k=8.617\times 10^{-5}\text{eV/K}$	$C_{ox} = 3.5\text{fF}/\mu\text{m}^2$	
$1\text{m} = 100\text{cm}$	$1\text{m} = 1\times 10^3\text{mm}$	$1\text{m} = 1\times 10^6\mu\text{m}$	$1\text{m} = 1\times 10^9\text{nm}$
$1\times 10^{12}\text{pm}$	$1\times 10^{15}\text{fm}$	$1\times 10^{18}\text{am}$	

Problem	Value	Score
1	20	
2	20	
3	15	
4	20	
5	20	
6	10	

Total	100/103	
-------	---------	--

PROBLEM 1

(20 Points)

An amplifier has an input impedance of $1\text{k}\Omega$, a forward transconductance of 10mS , and an output impedance of $5\text{M}\Omega$.

A. Draw the two-port model of this amplifier.

(5 Points)

B. Determine the ideal (unloaded) voltage gain of this amplifier.

(5 Points)

C. This amplifier is used to amplify the signal from one circuit and then pass that amplified signal to another circuit. The preceding stage has a Thevenin equivalent impedance of 100Ω . The following stage produces a load impedance of $10\text{k}\Omega$ for the amplifier. Determine the actual voltage gain of this resulting circuit (the input voltage is the Thevenin equivalent voltage from the preceding stage).

(5 Points)

D. Draw the source-referred small-signal equivalent model for an nFET with no body effect. Briefly explain how this fits the description of a two-port model, and determine all of the relevant two-port parameters (in terms of variables). (5 Points)

PROBLEM 2

(20 Points)

A cube of silicon material (2mm on each side) has the following band diagram.

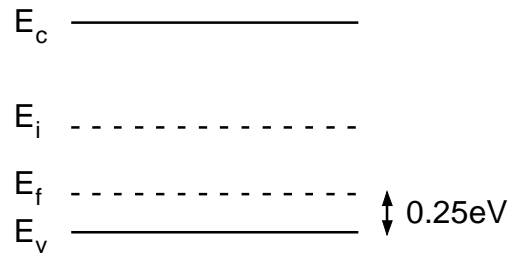

A. Is this n-type or p-type material? How do you know?

(4 Points)

B. What is the majority carrier and the majority carrier concentration?

(3 Points)

C. What is the minority carrier and the minority carrier concentration?

(3 Points)

D. What is the resistivity of the material?

(5 Points)

E. What is the probability that an electron is in the conduction band?

(5 Points)

PROBLEM 3

(15 Points)

For this problem, a MOS capacitor is composed of a polysilicon gate, an oxide (SiO_2), and a piece of p-type semiconductor. Assume that the flat-band voltage is $V_{FB} = 0\text{V}$. Determine which properties (A-F) apply to the following regions of operation of the MOS capacitor. Write the letter of the property (A-F) for *all that apply* to each region on the line under that region's name. Each region of operation may have multiple answers – write all that apply. Also, the properties (A-F) may be used more than once. Feel free to use the space below to justify your answers.

V_g	Accumulation	Depletion	Strong Inversion	Moderate Inversion	Weak Inversion
Poly					
SiO ₂					
p-type					
⊥					

<p>A. MOS Capacitor has linear capacitance</p> <p>B. MOS Capacitor has non-linear capacitance</p> <p>C. Contains a depletion region</p> <p>D. Number of carriers at the oxide-semiconductor interface \ll Number of fixed ions at the same interface</p> <p>E. Number of carriers at the oxide-semiconductor interface \gg Number of fixed ions at the same interface</p> <p>F. Contains electrons at the oxide-semiconductor interface</p>

PROBLEM 4

(20 Points)

Label everything in this problem! Label all dividing lines, all slopes, all regions of operation, and all intercept (x or y) values. In short, provide as much detail about the following plots as you can.

A. A pFET in an n-well process (i.e. p-type substrate) is shown below. You are asked to sketch a gate sweep and a drain sweep for the conditions shown below. Sketch the current on the axes that are provided below. To receive full credit, you must label all slopes, intercepts, dividing lines, regions of operation, etc. (10 Points)

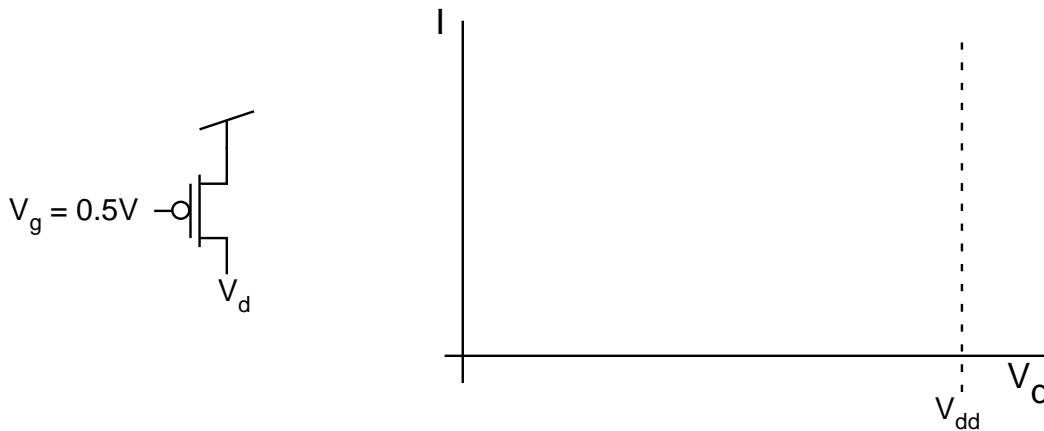
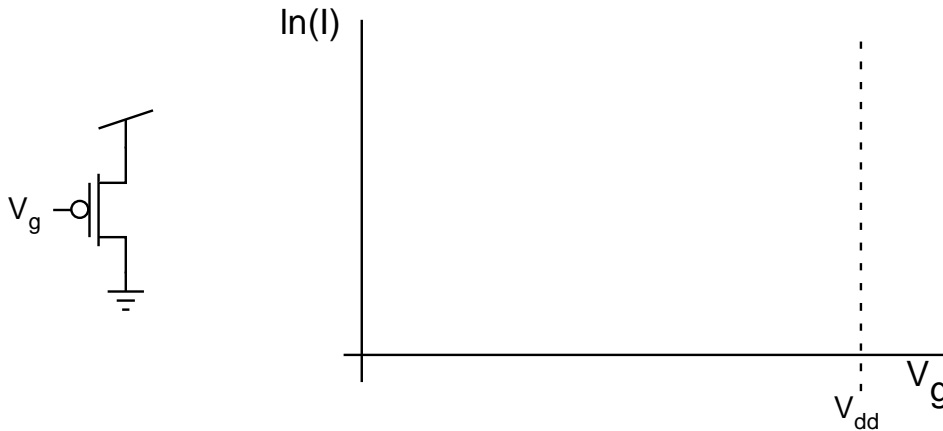

B. Sketch the transconductance efficiency (g_m/I_D) versus I_D for a pFET in this process in the area below. Use a log-log scale. Label *everything*, including all slopes, intercepts, transition points, and regions of inversion. (5 Points)

C. Draw a cross section of both an nFET and a pFET in this process. (5 Points)

PROBLEM 5

(20 Points)

For each of the following parts, determine the appropriate voltages and currents, and write them in the spaces that have been provided.

A.

(10 Points)

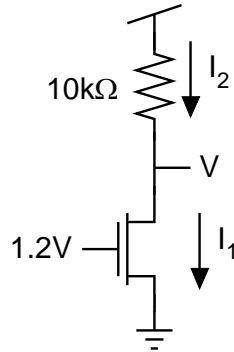

Assumptions for part A only.

- $V_{dd} - V > 0.01$
- The transistor operates in saturation

$I_1 =$ _____

$I_2 =$ _____

$V =$ _____

B.

(10 Points)

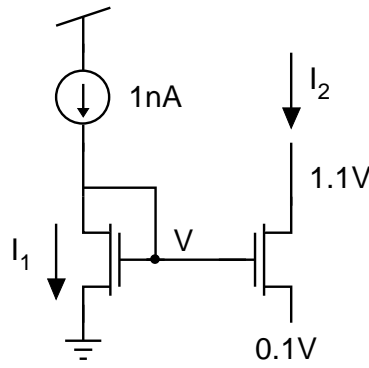

$I_1 =$ _____

$I_2 =$ _____

$V =$ _____

PROBLEM 6

(8 Points)

A. If you need to drive a resistive load with an opamp, how many stages would a typical opamp have? Briefly explain the purpose of each of those stages.

(5 Points)

B. Briefly explain how the bulk-referred and the source-referred small signal models differ.

(3 Points)