

SHORT COMMUNICATION

Recent African derivation of *Chrysomya putoria* from *C. chloropyga* and mitochondrial DNA paraphyly of cytochrome oxidase subunit one in blowflies of forensic importance

J. D. WELLS¹, N. LUNT² and M. H. VILLET²

¹Department of Biology, West Virginia University, Morgantown, West Virginia, U.S.A. and ²Department of Zoology & Entomology, Rhodes University, Grahamstown, South Africa

Abstract. *Chrysomya chloropyga* (Wiedemann) and *C. putoria* (Wiedemann) (Diptera: Calliphoridae) are closely related Afrotropical blowflies that breed in carrion and latrines, reaching high density in association with humans and spreading to other continents. In some cases of human death, *Chrysomya* specimens provide forensic clues. Because the immature stages of such flies are often difficult to identify taxonomically, it is useful to develop DNA-based tests for specimen identification. Therefore we attempted to distinguish between *C. chloropyga* and *C. putoria* using mitochondrial DNA (mtDNA) sequence data from a 593-bp region of the gene for cytochrome oxidase subunit one (COI). Twelve specimens from each species yielded a total of five haplotypes, none being unique to *C. putoria*. Therefore it was not possible to distinguish between the two species using this locus. Maximum parsimony analysis indicated paraphyletic *C. chloropyga* mtDNA with *C. putoria* nested therein. Based on these and previously published data, we infer that *C. putoria* diverged very recently from *C. chloropyga*.

Key words. Calliphoridae, *Chrysomya*, Diptera, blowflies, cytochrome oxidase, evolution, forensic entomology, molecular systematics, mitochondrial DNA, paraphyletic species, reciprocal mitochondrial DNA monophyly, South Africa, U.S.A.

Mitochondrial DNA (mtDNA) sequence data have often been advocated for species identification of forensically important insect specimens (Sperling *et al.*, 1994; Malgorn & Coquoz, 1999; Vincent *et al.*, 2000; Wallman & Donnellan, 2001; Wells & Sperling, 2001; Wells *et al.*, 2001). This approach is easier to accomplish in cases of reciprocal mtDNA monophyly corresponding to morphological species. When reciprocal mtDNA monophyly exists, a phylogenetic analysis of reference (identified) sequences plus the unknown sample will group the unknown with its own species, provided that the relevant species is included

among the reference sequences. This method can also produce an objective statement about the strength of this conclusion, based on measures of branch support such as a bootstrap value (Wells & Sperling, 2001).

Apparently some sister species have diverged too recently for detectable autapomorphies to result from mutations and lineage sorting (Avice, 2000). For example, Wallman & Donnellan (2001) were unable to distinguish between the cytochrome oxidase haplotypes of certain Australian *Calliphora* species. For purposes of forensic science, the molecular systematics of very closely related carrion-insect species deserve close attention because these specimens are difficult to identify using morphological criteria. Two such Diptera are the 'coppery-tailed blowfly' *Chrysomya chloropyga* (Wiedemann) and the 'tropical latrine blowfly' *Chrysomya putoria* (Wiedemann), both originally Afrotropical in

Correspondence: Dr J. D. Wells, Department of Biology, West Virginia University, 53 Campus Drive, Morgantown, WV 26506, U.S.A. Fax: +1 304 293 6363; e-mail: jdewells@mail.wvu.edu

distribution (Zumpt, 1965). During the 1970s, *C. putoria* invaded Brazil (Guimarães *et al.*, 1978; Laurence, 1981, 1986), and has spread at least as far north as Panama (Wells & Sperling, 2001). Synanthropically they often reach very high population densities (Smit, 1931; Guimarães *et al.*, 1979) and they breed in carrion (Smit, 1931; Ulyett, 1950; Greenberg & Szyska, 1984; Baumgartner & Greenberg, 1985; Meskin, 1986), including human corpses (Lothe, 1964; Louw & van der Linde, 1993).

Although both Zumpt (1965) and Paterson (1968) found barriers to gene flow between the two phenotypes, *C. chloropyga* and *C. putoria*, only the latter concluded that they were separate species (Zumpt, 1972; Guimarães *et al.*, 1978). Zumpt was unable to find differences in the male genitalia and noted the existence of 'intermediate forms' that are now thought to represent variants of *C. putoria*. Subsequent taxonomic treatments such as Pont (1980) and Dear (1985) listed the two names as synonyms. However, work by Paterson (1968) and Erzinclioğlu (1987) revealed a suite of morphological, behavioural, ecological and developmental characters that can be used separate them, although it is still not possible to distinguish between the eggs and early larval instars of these two taxa. Finding specific diagnostic characters for these life stages would be useful for forensic entomologists and may help to resolve their taxonomic status. Therefore we evaluated the utility of mtDNA sequence data for distinguishing *C. chloropyga* from *C. putoria*.

Wild adult flies collected in Grahamstown, Eastern Cape, South Africa were identified as either *C. chloropyga* or *C. putoria* based on the pronotal and abdominal tergite coloration patterns (Paterson, 1968). Twelve individuals of each form were used for molecular analysis. Specimens were captured by hand-net at fresh carrion and immediately preserved in 95% ethanol, replaced two to three times soon after collection to maintain a high concentration and therefore promote the dehydration of specimens. *Calliphora chloropyga* were collected next to a road at the edge of the town during July 2000 (during a period in which no *C. putoria* were observed), and *C. putoria* were collected on the Rhodes University campus during April 1999 (during a period in which no *C. chloropyga* were observed). The remainder of each specimen has been deposited as a voucher in the South African National Diptera Collection, Natal Museum, Pietermaritzburg. Homologous *C. putoria* sequences from GenBank Accession numbers AF295554 (Wells & Sperling, 2001) and AF352790 were included as in-group taxa in the analysis. Both sequences were from the population introduced to Latin America. As out-groups, we used the sequences of *C. albiceps* (AF083657), *C. norrisi* (AF295552) and *C. semimetallica* (AF295562) described previously (Wells & Sperling, 2001).

DNA was extracted from thoracic muscle of each *Chrysomya* specimen using a DNeasy™ Tissue Kit (QIAGEN Inc., Valencia, CA, U.S.A.) following the manufacturer's instructions. Polymerase chain reaction (PCR) and cycle sequencing procedures used in this study were described in detail by Wells & Sperling (2001). The primer pairs were C1-J-2183/C1-N-2659 and C1-J-2495/

C1-N-2800. The sequence was determined for only one strand of a given PCR product. Sequences were confirmed and aligned manually using Sequence Navigator (Applied Biosystems, Foster City, CA, U.S.A.). Each DNA sequence was translated to the amino acid sequence using Sequencher (Gene Codes Corp., Ann Arbor, MI, U.S.A.). Phylogenetic analyses were performed using the default parameters in PAUP 4.0b8 (Swofford, 1998).

From the mtDNA of each specimen, we sequenced 593 bp of COI corresponding to base positions 2275–2776 of *Drosophila yakuba* (GenBank Accession number NC_001322; Clary & Wolstenholme, 1985). The 24 specimens yielded five haplotypes (i.e. mitochondrial genotypes) designated A–E (Table 1). The two haplotypes (C and D) recovered from *C. putoria* were also recovered from some *C. chloropyga* (Fig. 1), so neither of these haplotypes was found to be unique to *C. putoria*. The deep divergence of mtDNA COI between specimens of *C. chloropyga* is more than twice that found in a worldwide survey of *C. rufifacies* (Wells & Sperling, 1999). Both the high frequency and basal position of haplotype E suggest that this is the oldest in our sample (Crandall & Templeton, 1996). All of the polymorphic sites listed in Table 1 represent silent substitutions, i.e. all haplotypes code for the same amino acid sequence. The five haplotypes have been deposited in the GenBank sequence database (<http://www.ncbi.nlm.nih.gov/>, Accession numbers AY139691–5).

From the mtDNA data currently available, one cannot reliably distinguish between *C. chloropyga* and *C. putoria* using this region of COI. Evidently the mtDNA of *C. chloropyga* is not monophyletic and no haplotype unique to *C. putoria* was found. Hence COI-based identification is ambiguous for '*C. chloropyga* or *C. putoria*' except in geographical areas where only one of these forms is known to occur, such as *C. putoria* in the New World, based on bioecological and morphological characters (Wells & Sperling, 2001).

Additional mtDNA data should improve phylogenetic resolution within the clade with haplotypes A–D (Fig. 1) and might determine new haplotypes. If reciprocal mtDNA monophyly exists between *C. putoria* mtDNA and a particular *C. chloropyga* mtDNA lineage, then unambiguous

Table 1. Five mitochondrial cytochrome oxidase one (COI) haplotypes, designated A–D, observed in specimens of *Chrysomya chloropyga* and *C. putoria*. Vertical alignments represent observed polymorphic base positions. Column numbers correspond to those of the GenBank records (Accession numbers AY139691–5). A dash indicates the same base found in haplotype A (AY139691).

	1	1	1	1	1	1	2	3	3	4	4	5	5
Haplotype	0	1	5	7	8	9	8	6	8	0	6	1	1
	3	5	1	2	4	6	9	4	8	6	0	2	7
A	G	A	T	A	T	C	T	T	T	T	G	T	G
B	–	–	–	G	–	–	–	–	–	A	–	–	–
C	A	–	–	–	–	–	–	–	–	A	–	–	–
D	–	–	–	–	–	–	–	–	–	A	–	–	–
E	–	G	A	–	C	T	C	C	C	A	A	C	A

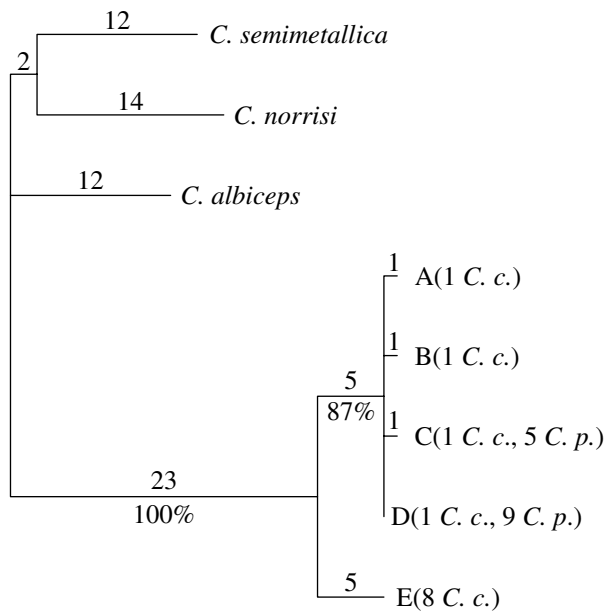

Fig. 1. One of six equally most parsimonious trees (exhaustive search) for mtDNA haplotypes from specimens of *Chrysomya chloropyga* (*C. c.*) and *C. putoria* (*C. p.*). The analysis was based on a 593-bp region of the cytochrome oxidase one (COI) gene. This phylogram shows length values above branches and majority bootstrap support below two branches (from 1000 replicates), based on 12 individuals of each species from South Africa, newly sequenced for this study, plus two previously published sequences of *C. putoria* from South America (see text). Out-group data for three other species of *Chrysomya* from Wells & Sperling (2001).

DNA-based identification of these two forms within an area of sympatry may be possible. Unfortunately, for some investigations this would be impractical because any genotyping procedure using a locus greater than about 400 bp in length is impracticable with a poorly preserved specimen. Despite the genetic similarity of these flies, the weight of current evidence strongly indicates that *C. putoria* has developed a distinct phenotype and permanent evolutionary independence from *C. chloropyga*, i.e. assortative mating (Paterson, 1968). Therefore it serves the purpose of most biologists to consider them to be separate species, albeit paraphyletic. The most parsimonious interpretation of their mtDNA is that *C. chloropyga* carries the more plesiomorphic sequences of COI. One estimate of insect mtDNA sequence change is ~2.3% per million years (Brower, 1994). If such a rate applies to this pair of Diptera, the COI evidence indicates divergence of *C. putoria* from *C. chloropyga* within the last few thousand years.

Acknowledgements

Support was provided by the US National Institute of Justice Grant 99-IJ-CX-0034 to J.D.W., and the South African National Research Foundation and Rhodes

University Joint Research Council grants to M.H.V. and N.L. Laboratory assistance was provided by J. Howard and R. Cosme, University of Alabama at Birmingham.

References

- Awise, J.C. (2000) *Phylogeography. The History and Formation of Species*. Harvard University Press, Cambridge, MA.
- Baumgartner, D.L. & Greenberg, B. (1985) Distribution and medical ecology of the blow flies (Diptera: Calliphoridae) of Peru. *Annals of the Entomological Society of America*, **78**, 565–587.
- Brower, A.V.Z. (1994) Rapid morphological radiation and convergence among races of the butterfly *Heliconius erato* inferred from patterns of mitochondrial DNA evolution. *Proceedings of the National Academy of Sciences U.S.A.*, **91**, 6491–6495.
- Clary, D.O. & Wolstenholme, D.R. (1985) The mitochondrial DNA molecule of *Drosophila yakuba*: nucleotide sequence, gene organization, and genetic code. *Journal of Molecular Evolution*, **22**, 252–271.
- Crandall, K.A. & Templeton, A.R. (1996) Applications of intraspecific phylogenetics. *New Uses for New Phylogenies* (ed. by P.H. Harvey, A.J. Leigh Brown, J. Maynard Smith and S. Nee), pp. 81–99. Oxford University Press, Oxford.
- Dear, J.P. (1985) A revision of the New World Chrysomyini (Diptera: Calliphoridae). *Revista Brasileira Zoologia*, **3**, 109–169.
- Erzinclioğlu, Y.Z. (1987) The larvae of some blowflies of medical and veterinary importance. *Medical and Veterinary Entomology*, **1**, 121–125.
- Greenberg, B. & Szyska, M.L. (1984) Immature stages and biology of fifteen species of Peruvian Calliphoridae (Diptera). *Annals of the Entomological Society of America*, **77**, 488–517.
- Guimarães, J., do Prado, A. & Linhares, A.X. (1978) Three newly introduced blowfly species in southern Brazil (Diptera, Calliphoridae). *Revista Brasileira Entomologia*, **22**, 53–60.
- Guimarães, J., do Prado, A. & Buralli, G. (1979) Dispersal and distribution of three newly introduced species of *Chrysomya* Robineau-Desvoidy in Brazil. *Revista Brasileira Entomologia*, **23**, 245–255.
- Laurence, B.R. (1981) Geographical expansion of the range of *Chrysomya* blowflies. *Transaction of the Royal Society of Tropical Medicine and Hygiene*, **75**, 130–131.
- Laurence, B.R. (1986) Old World blowflies in the New World. *Parasitology Today*, **2**, 77–79.
- Lothe, F. (1964) The use of larva infestation in determining the time of death. *Medicine, Science, and the Law*, **4**, 113–115.
- Louw, S.V.D.M. & van der Linde, T.C. (1993) Insects frequenting decomposing corpses in central South Africa. *African Entomology*, **1**, 265–269.
- Malgorn, Y. & Coquoz, R. (1999) DNA typing for identification of some species of Calliphoridae. An interest in forensic entomology. *Forensic Science International*, **102**, 111–9.
- Meskin, I. (1986) Factors affecting the coexistence of blowflies (Diptera: Calliphoridae) on the Transvaal Highveld, South Africa. *South African Journal of Science*, **82**, 244–250.
- Paterson, H.E.H. (1968) Evolutionary and population genetical studies of certain Diptera. PhD Thesis, University of the Witwatersrand, Johannesburg.
- Pont, A.C. (1980) Family Calliphoridae. *Catalogue of the Diptera of the Afrotropical Region* (ed. by R.W. Crosskey), pp. 779–800. British Museum (Natural History), London.

- Smit, B. (1931) A study of the sheep blow-flies of South Africa. *Report of the Director of Veterinary Services and Animal Industry, Union of South Africa*, **17**, 299–421.
- Sperling, F.A.H., Anderson, G.S. & Hickey, D.A. (1994) A DNA-based approach to the identification of insect species used for postmortem interval estimation. *Journal of Forensic Sciences*, **39**, 418–427 [erratum by Wells, J.D. & Sperling, F.A.H. (2000) *Journal of Forensic Sciences*, **45**, 6].
- Swofford, D.L. (1998) *PAUP**. *Phylogenetic Analysis Using Parsimony (*and other methods)*, Version 4. Sinauer, Sunderland, MA, U.S.A.
- Ullyett, G.C. (1950) Competition for food and allied phenomena in sheep-blowfly populations. *Philosophical Transactions of the Royal Society of London*, **234**, 77–174.
- Vincent, S., Vian, J.M. & Carlotti, M.P. (2000) Partial sequencing of the cytochrome oxidase b subunit gene I: a tool for the identification of European species of blow flies for postmortem interval estimation. *Journal of Forensic Sciences*, **45**, 820–823 [correction by Wells, J.D. & Sperling, F.A.H. (2000) *Journal of Forensic Science*, **45**, 6].
- Wallman, J.F. & Donnellan, S.C. (2001) The utility of mitochondrial DNA sequences for the identification of forensically important blowflies (Diptera: Calliphoridae) in southeastern Australia. *Forensic Science International*, **120**, 60–67.
- Wells, J.D. & Sperling, F.A.H. (1999) Molecular phylogeny of *Chrysomya albiceps* and *C. rufifacies* (Diptera: Calliphoridae). *Journal of Medical Entomology*, **36**, 222–226.
- Wells, J.D. & Sperling, F.A.H. (2001) DNA-based identification of forensically important Chrysomyinae (Diptera: Calliphoridae). *Forensic Science International*, **120**, 109–114.
- Wells, J.D., Pape, T. & Sperling, F.A.H. (2001) DNA-based identification and molecular systematics of forensically important Sarcophagidae. *Journal of Forensic Sciences*, **46**, 1098–1102.
- Zumpt, F. (1965) *Myiasis in Man and Animals in the Old World*. Butterworths, London.
- Zumpt, F. (1972) Notes on Diptera (Sarcophagidae, Calliphorinae) from the Ethiopian geographical region. *Zeitschrift für Angewandte Zoologie*, **59**, 439–445.